

Embedded and Ambient Systems

2023.09.19.

Development Board



Méréstechnika és
Információs Rendszerek
Tanszék

Main parts of the development board

■ EFM32GG-STK3700

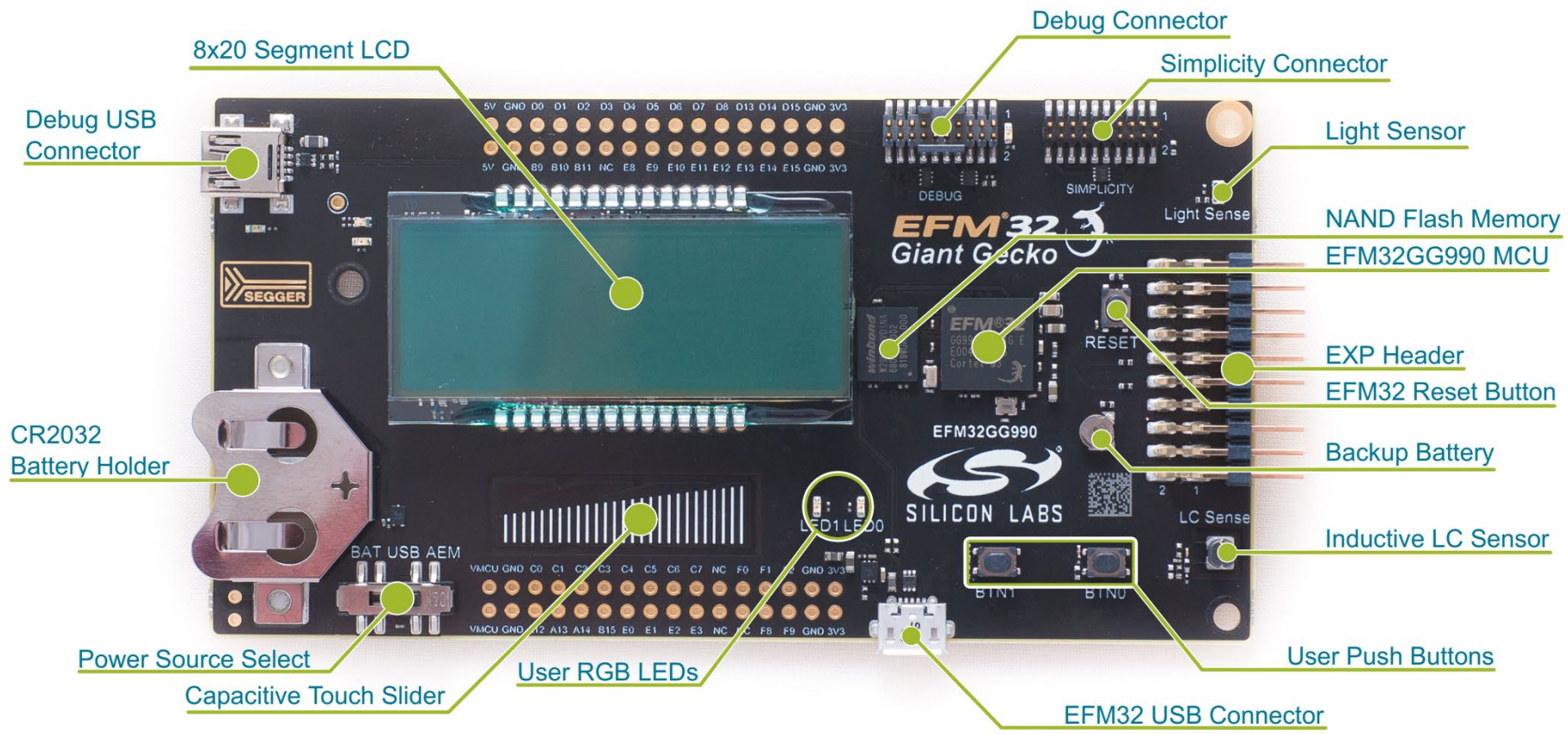

Main parts of the development board

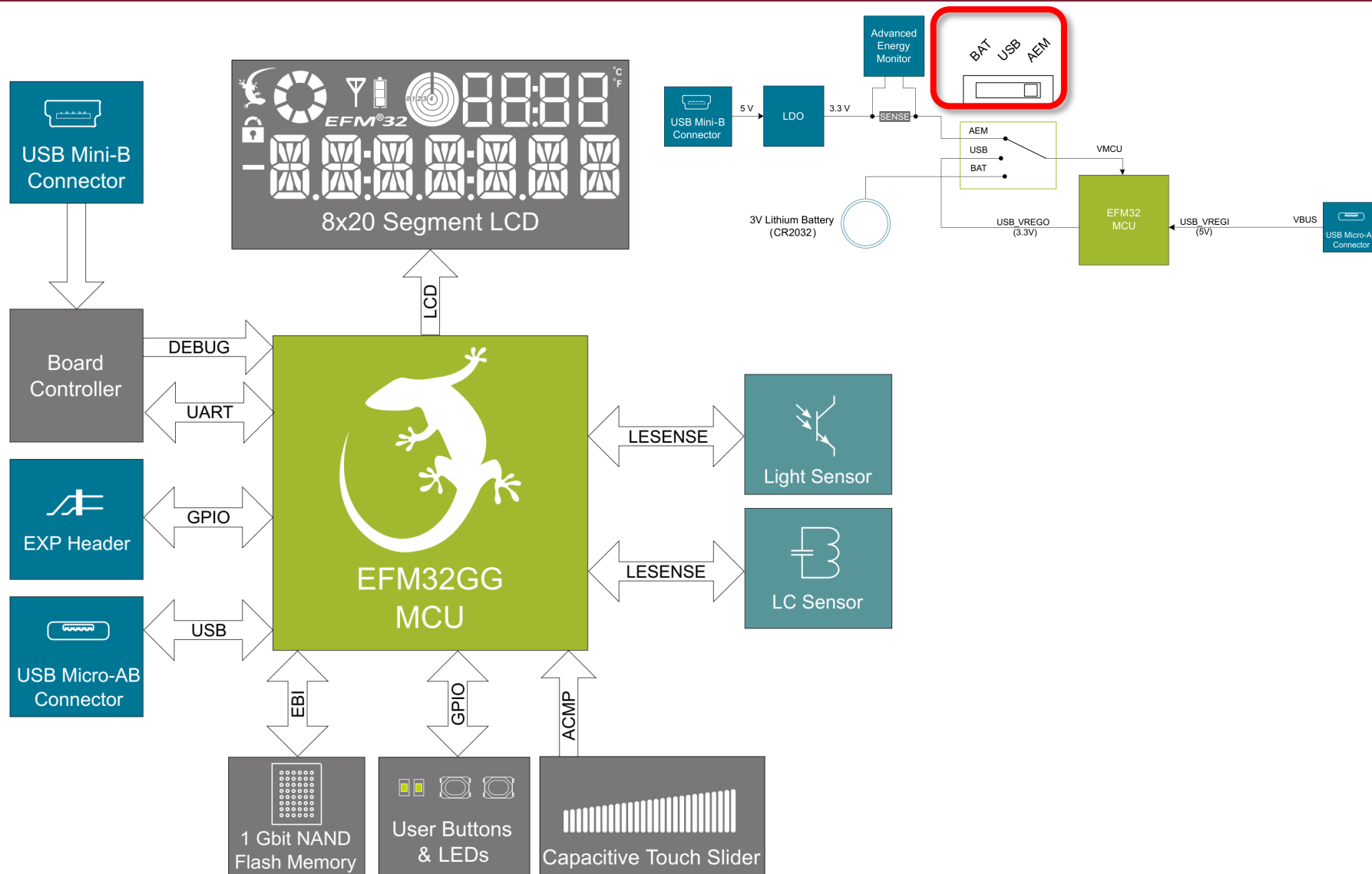

Main parts of the development board

Push buttons and LEDs

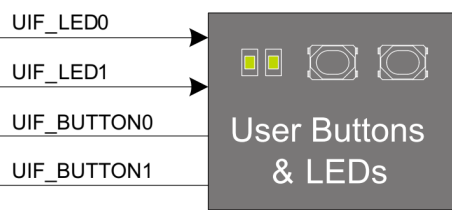
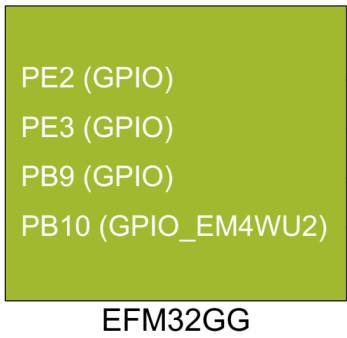

Avoidance of push button bounce effect (RC filter: R101+C100)

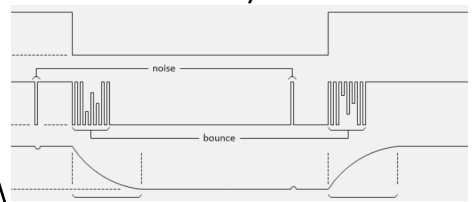

Current limiting protection resistance if pin is set as output

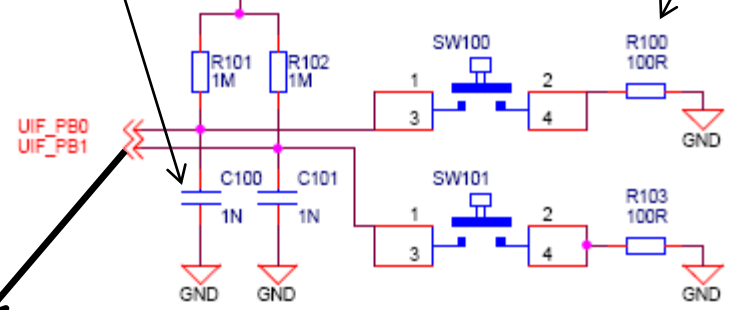
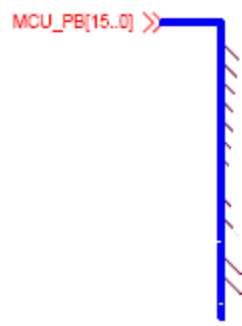

LED shunt resistance: $(3.3V-2V)/3k\Omega \approx 0.4mA$
 $\sim 1mA \dots 10mA$ current, and $1.5 \dots 2V$ voltage is expected as opening voltage of the LED

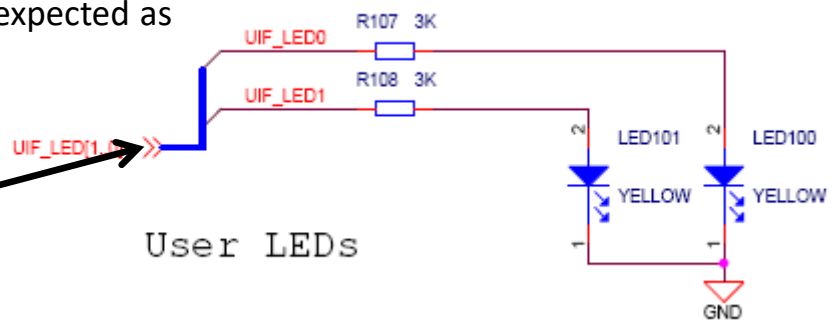

LCD display

■ LCD display

- Controller has integrated driver for the LCD as a dedicated peripheral
- Alphanumerical and special characters and symbols

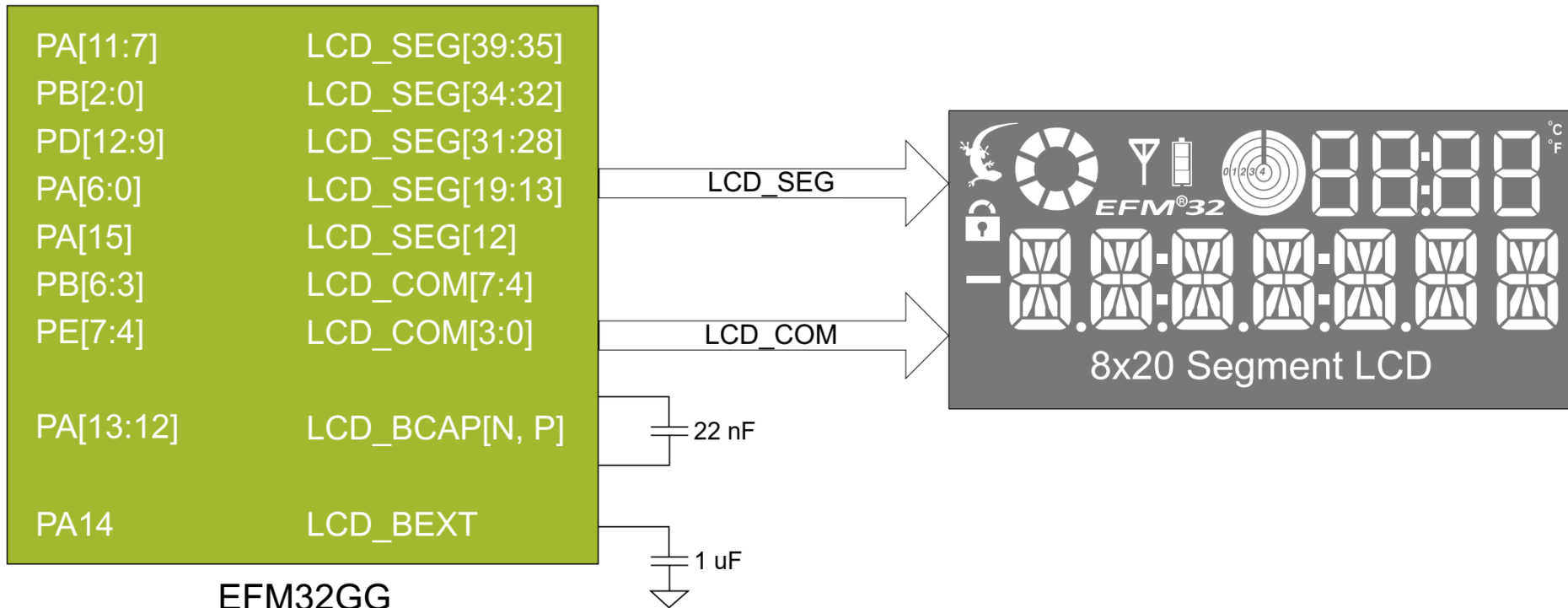

EFM32GG

Photosensor

- Implemented by a phototransistor
 - Light: „basis current”
- Luminance in an office: approx. 400 lux →

0.1mA →

$$U_{\text{sense}} = 22 \text{ k}\Omega * 0.1 \text{ mA} = 2.2 \text{ V} :$$

Ok, for the ADC?

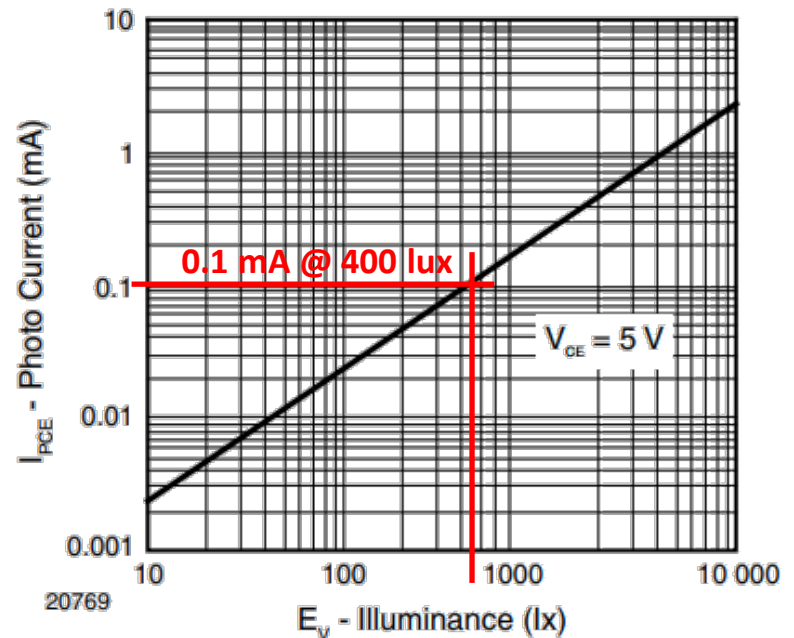
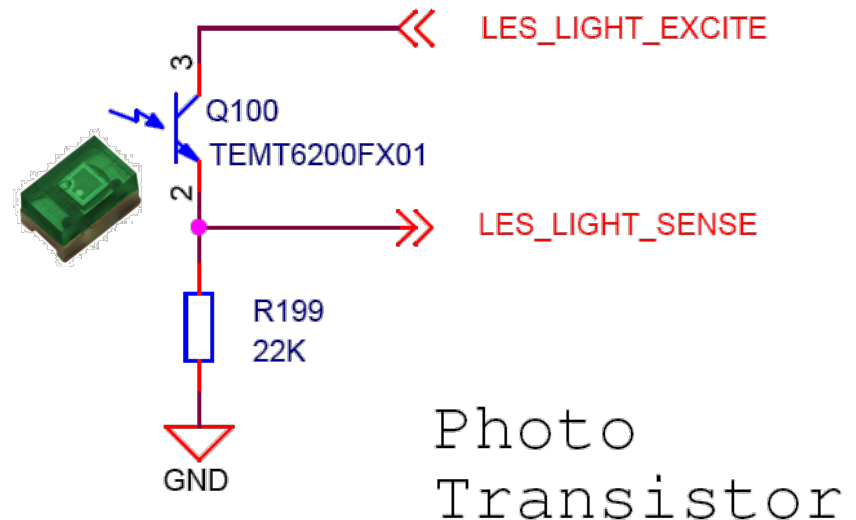

LC metal sensor – operation principle

- External LC circuit is excited
- Oscillation time is measured
- The larger the decay time, the larger the quality factor of LC resonant circuit, i.e., the smaller the energy loss of the inductor
- If a metal object is in the vicinity of the inductor its energy loss gets larger, i.e., the decay time of the oscillation is reduced
- The effective range is a few millimeters

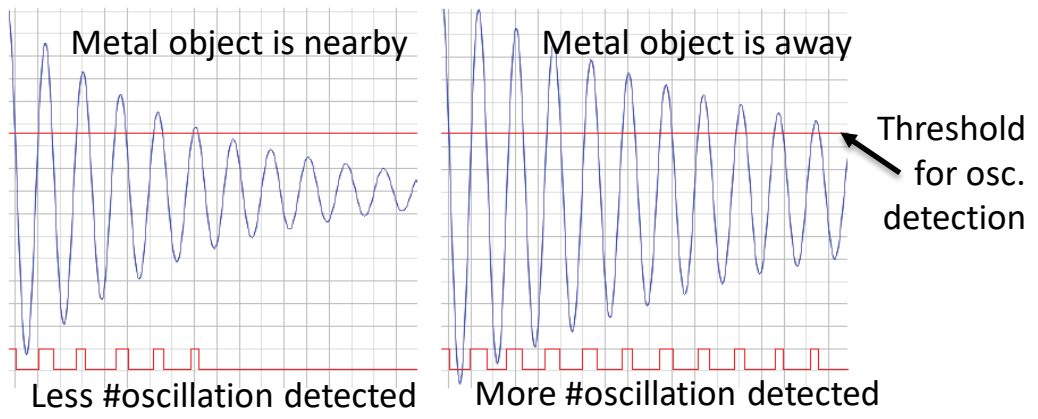
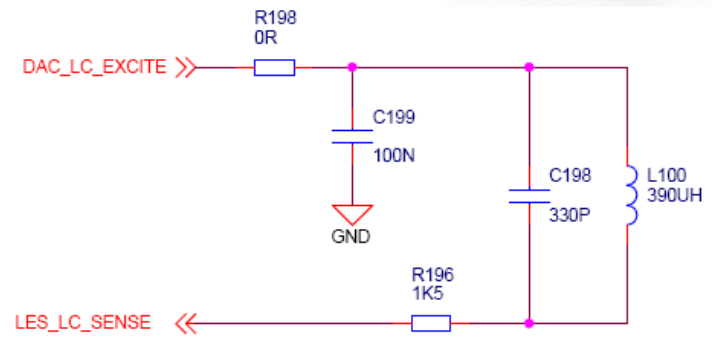
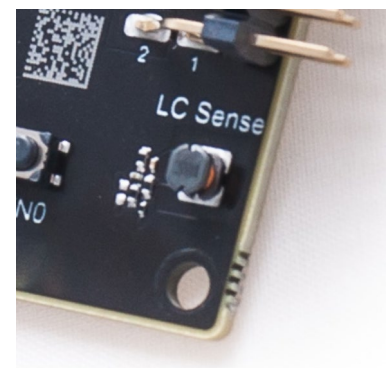
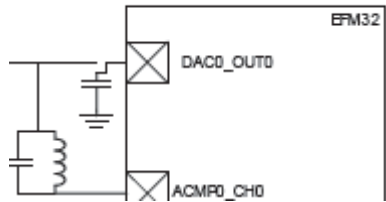

Touch sensor

■ Touch slider

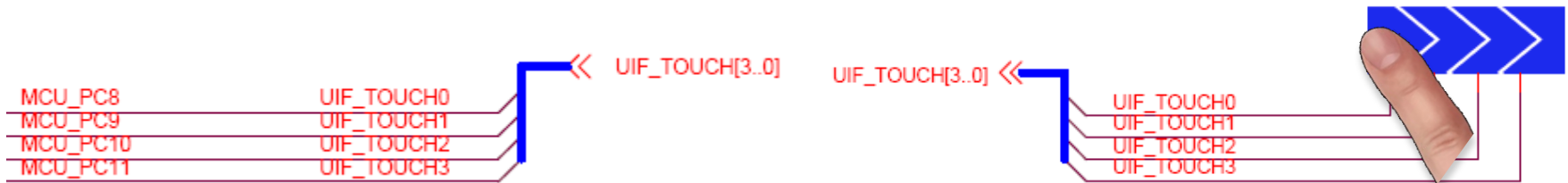
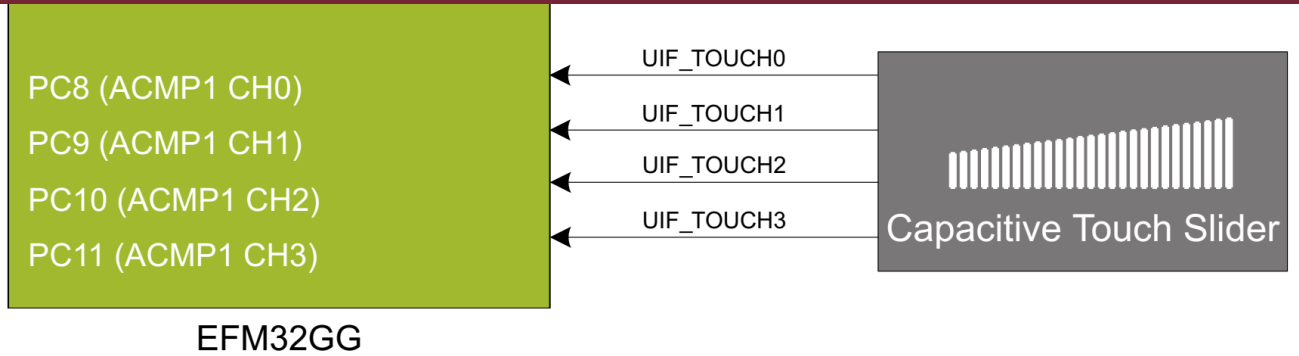

Sensor segments on the PCB.
GND layer is not allowed to be placed underneath.

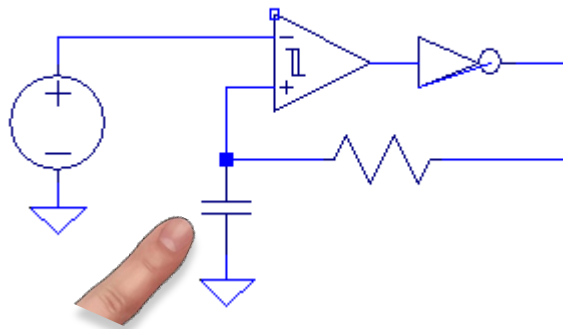

RC oscillator on the PCB.
Approaching finger towards copper foil increases its capacity that detunes frequency. The larger the touched area the larger the capacity → frequency decreased

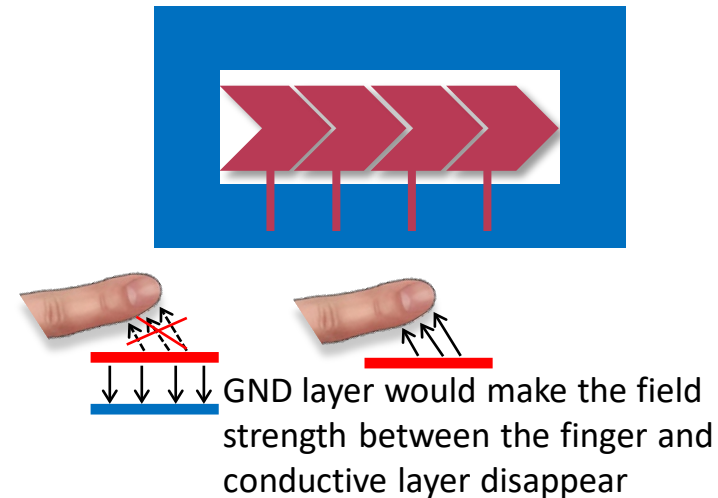

Touch sensor

■ Touch slider

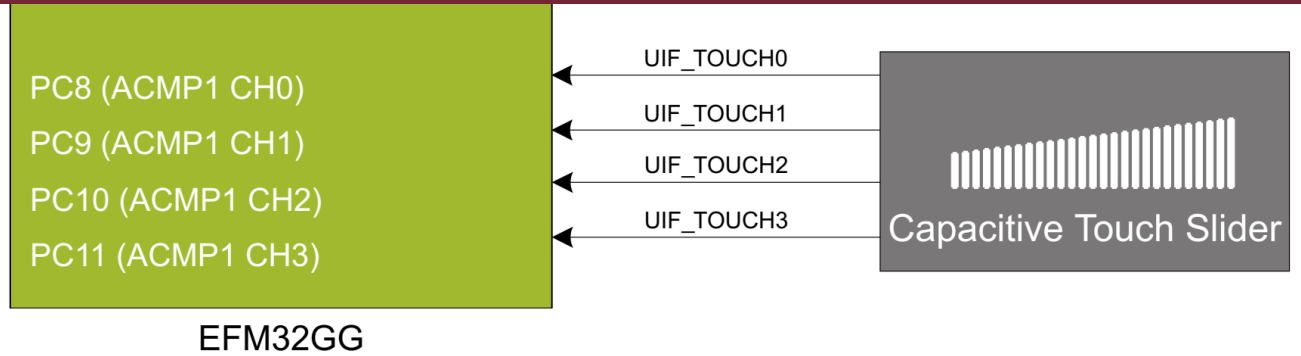

Excited by reference voltage the output of the comparator is Low \rightarrow output of inverter is High, i.e., capacitor is being charged

Exceeding the reference voltage output of the comparator gets High \rightarrow output of inverter is Low, i.e., capacitor is being discharged until lower hysteresis level is reached.

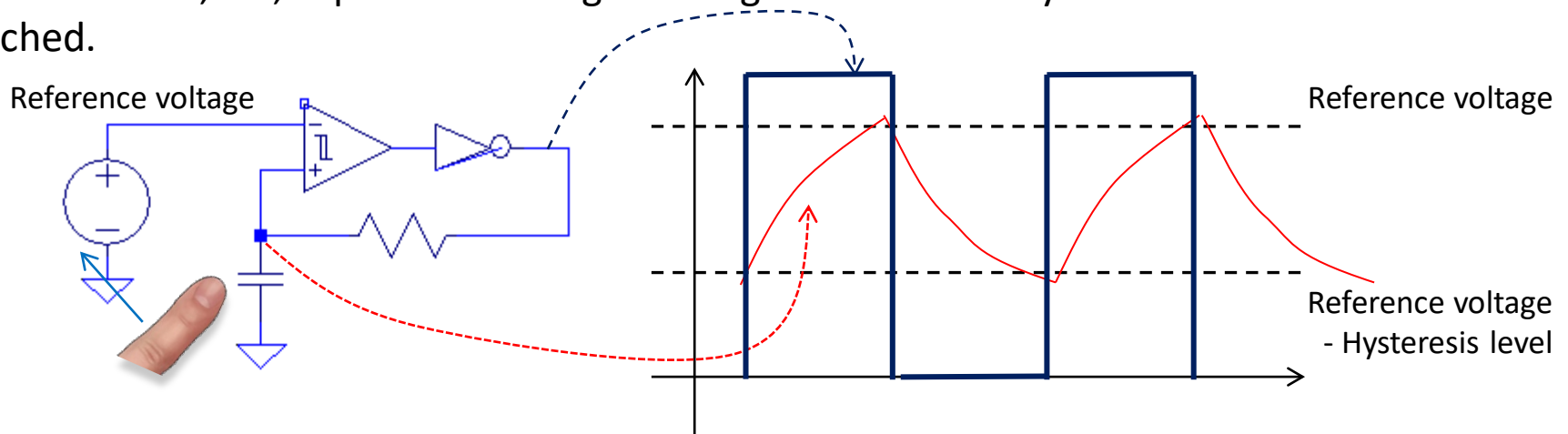

When the finger is close the capacity gets higher \rightarrow takes more time for charging/discharging \rightarrow freq. changed \rightarrow position sensed

Measurement of current consumption

- Voltage of a small value resistance is measured (see 4.7Ω resistance)
- AEM: Advanced Energy Monitor

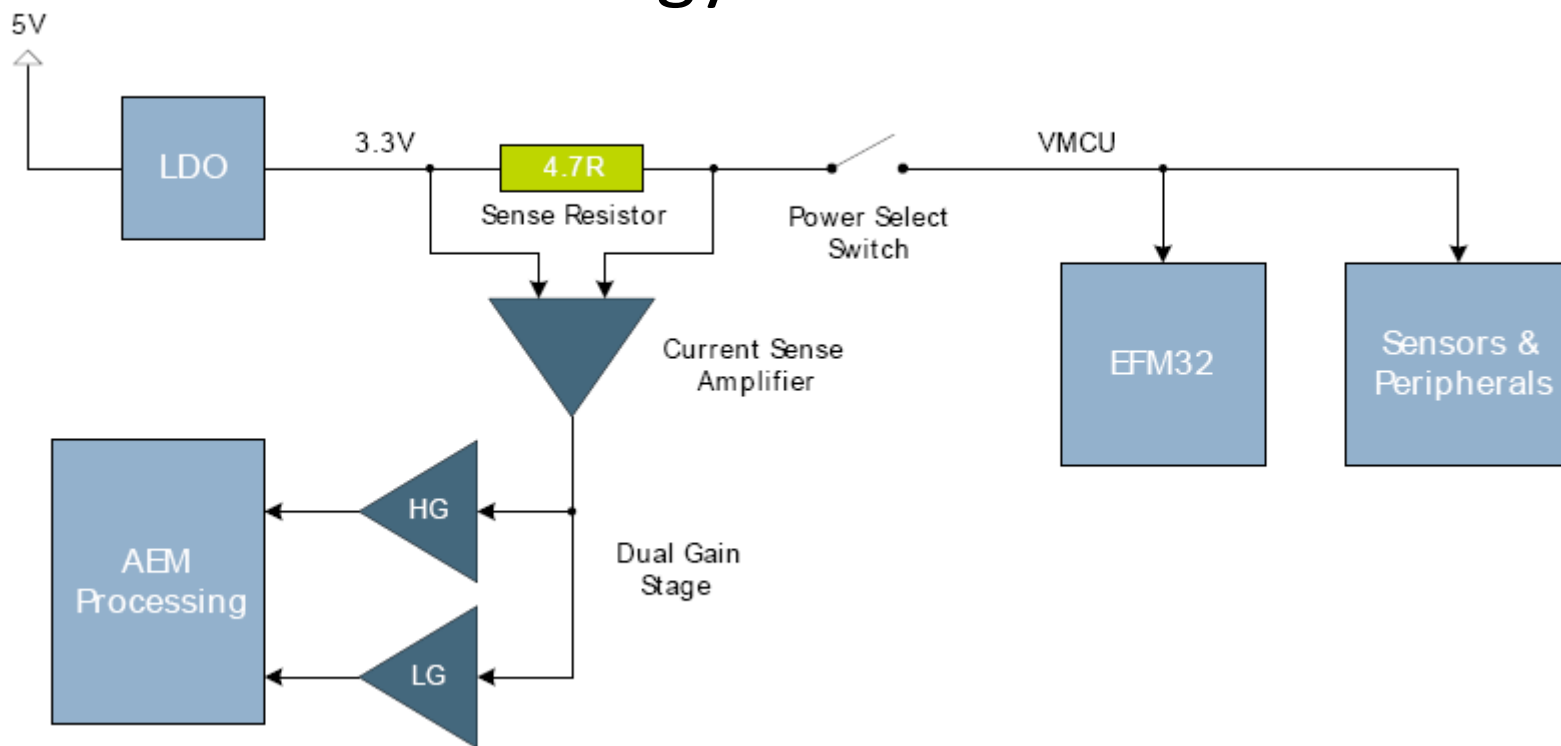

Measurement of current consumption

- Voltage of a small value resistance is measured (see 4.7Ω resistance)

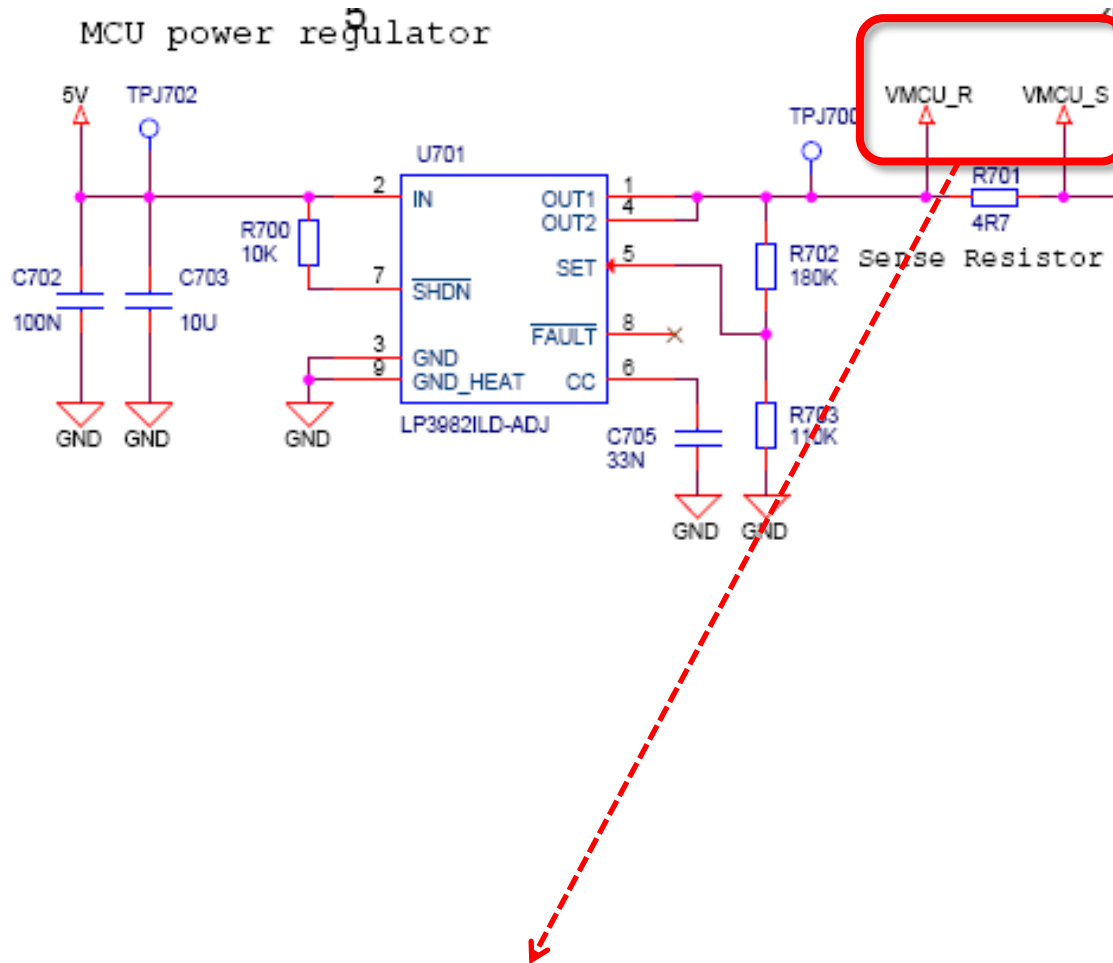

Measurement of current consumption

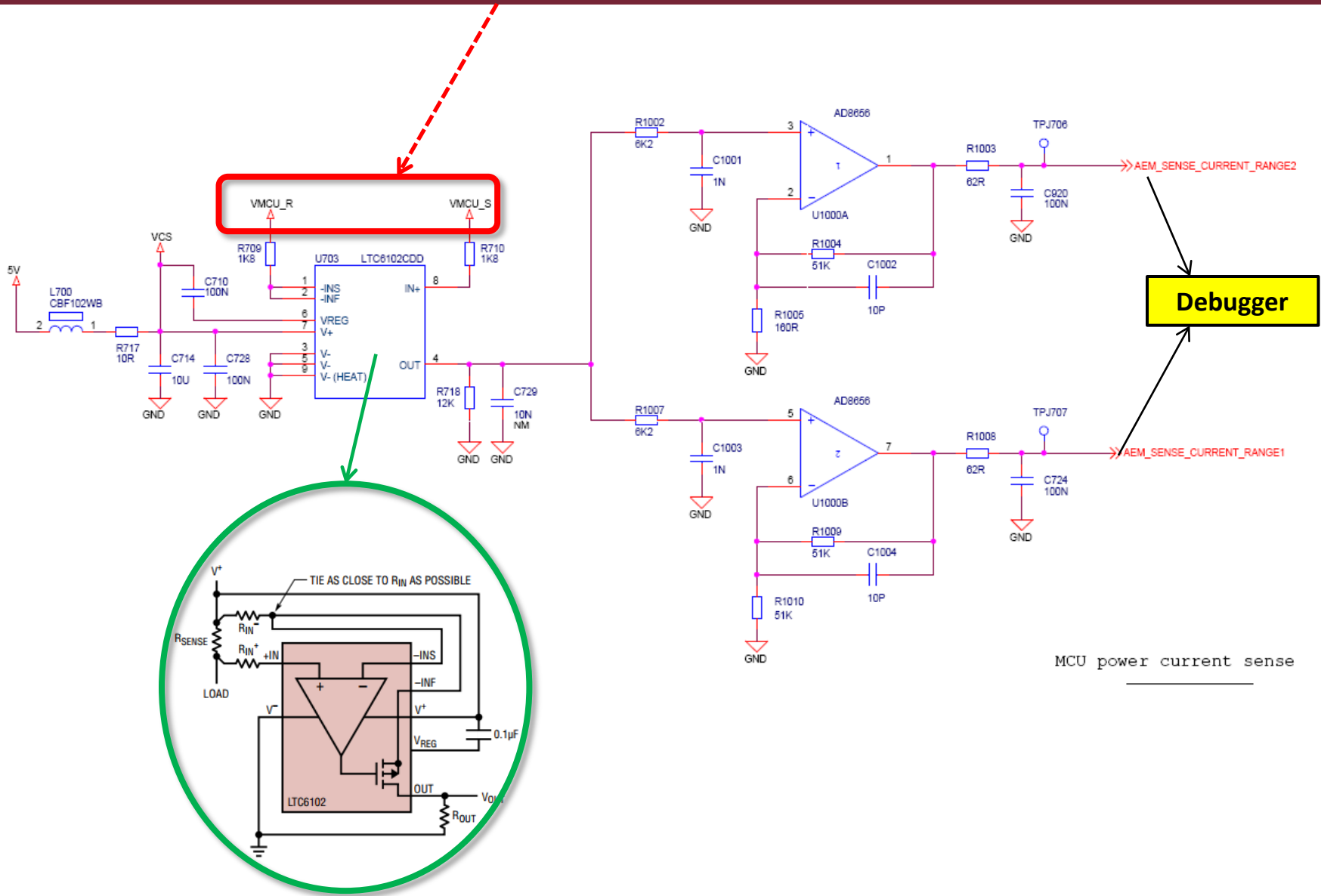

Debug interface

- Connection between:
Development environment
and uC
- Debugger has access to
internal registers and
memory of uC via its debug
port
- A debugger is a separated
circuitry, an other
uC-based unit connected
to the dedicated interface
of the main uC
- UART communication is
possible

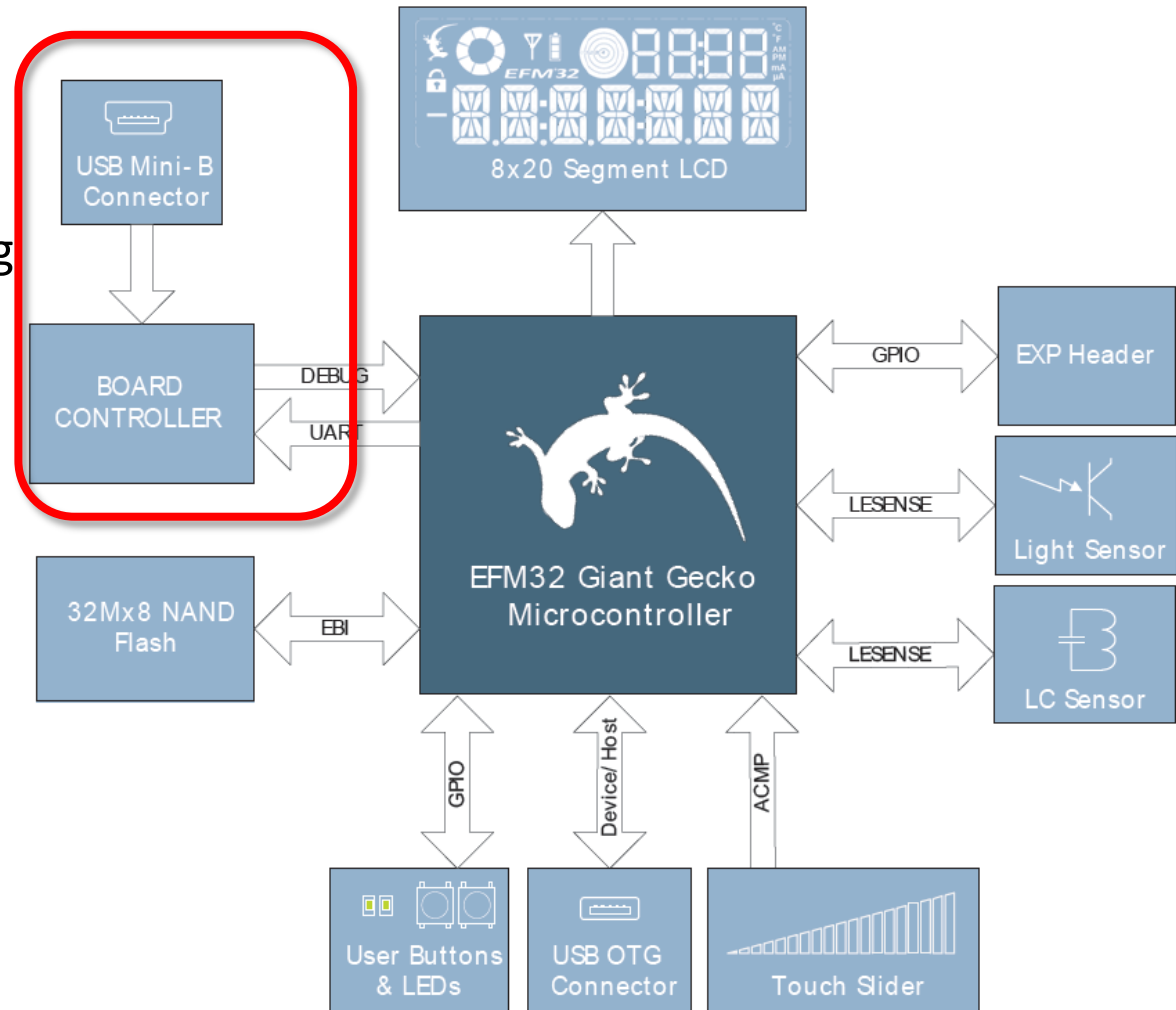

Block diagram of the uC

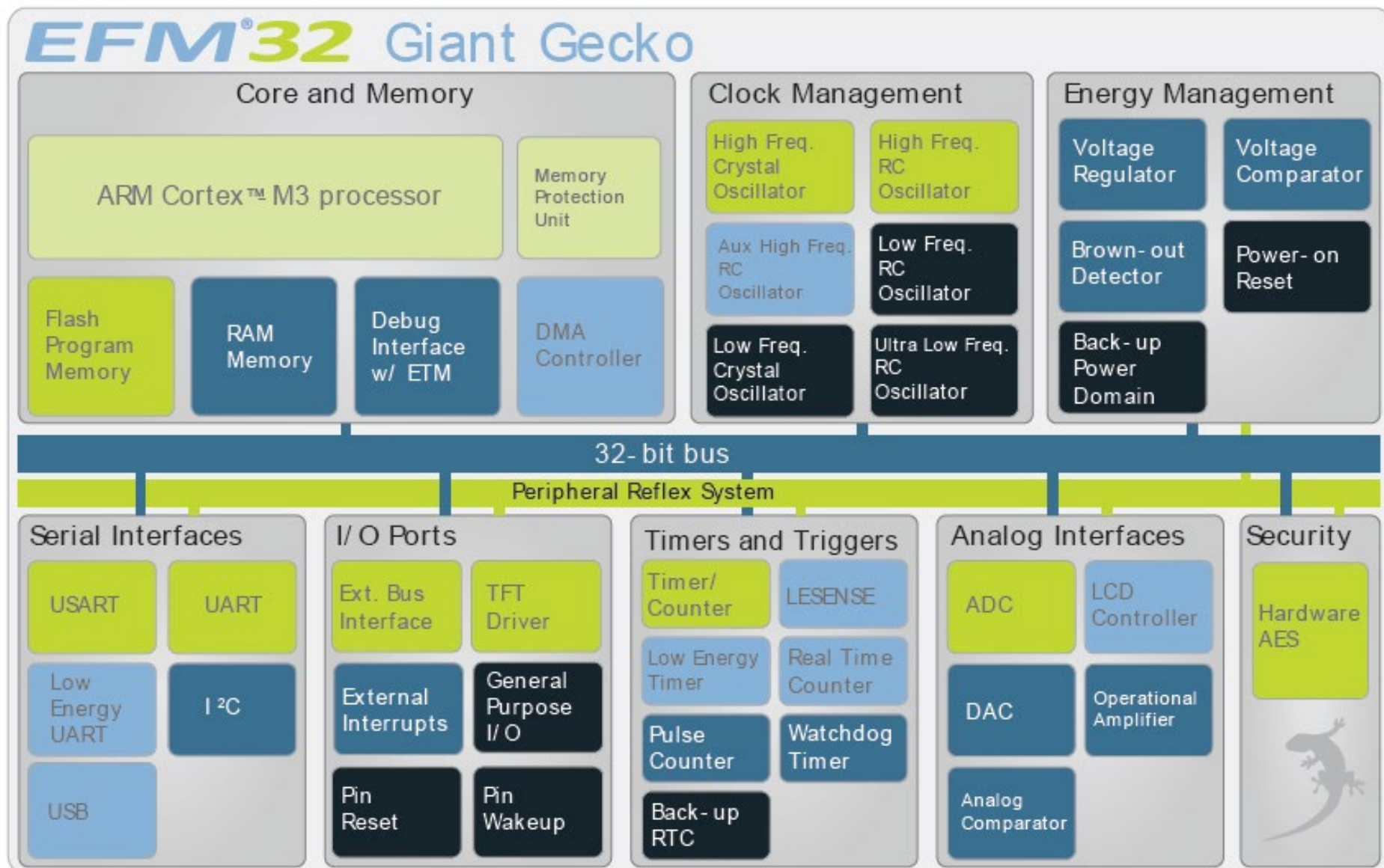

Block diagram of the uC

- Core: ARM Cortex-M3
- 32-bit bus is used to connect peripherals:
 - Clock management
 - Energy management
 - Serial comm lines
 - GPIO lines
 - Timer
 - Analog units (ADC, DAC, comparator, op. amplifier)
 - HW-based security features (Advanced Encryption Standard (AES))



Blocks of uC - core

- Core: ARM Cortex-M3
- Maximum 48 MHz clock frequency
 - Internal oscillator:
 - Max. 28 MHz,
 - Autonomous operation, even without external clock source
 - Implemented by RC oscillator: inaccurate, where accuracy is needed external crystal oscillator as clock source is better
- Internal peripherals
 - Interrupt control (Nested Vector Interrupt: NVIC)
 - State controller (System Control Block: SCB)
 - System timer: SysTick timer (24 bit) (safe timer for op. system)
 - Memory Protection Unit (MPU): to protect certain memory blocks (i.e. operation system)

Blocks of uC - core

▲ : Can be used for debugging

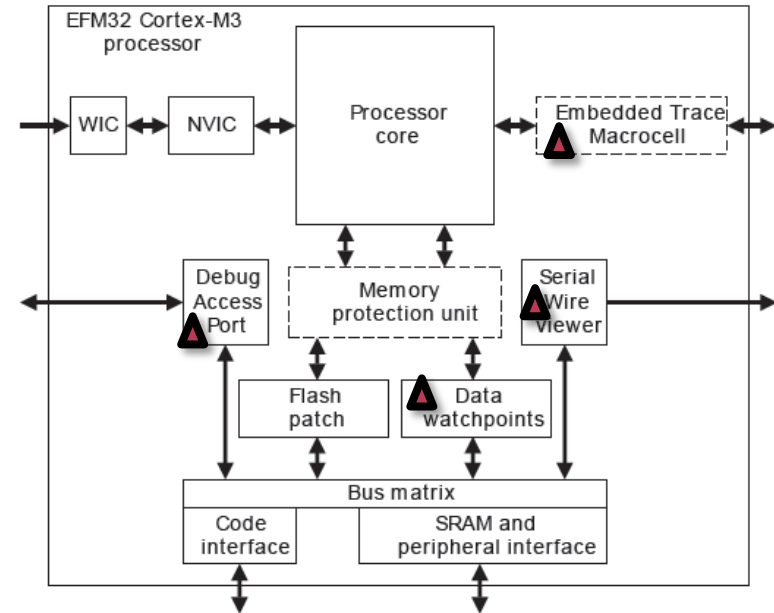

■ Internal blocks

- Interrupt control (Nested Vector Interrupt: NVIC)
 - WIC: wakeup interrupt controller: to save energy
- State Control (System Control Block: SCB)
- System timer: SysTick timer (24 bit)
- Memory Protection Unit (MPU): to protect certain memory blocks (i.e. operation system)
- Serial Wire Viewer, DAP: debug ports

■ Instruction set: 32-bit, but 16-bit (Thumb) mode is also possible

Memory map

- 4 GB addressable memory (since 32-bit uC, but that amount of memory is not present → use of external memory is possible)
- Main memory blocks:
 - Code memory: Flash
 - Data memory: SRAM
 - Registers for peripherals (registers nested into the memory)
 - Used to configure peripherals
 - Bit band: certain bits of the registers are mapped into other registers for simpler access

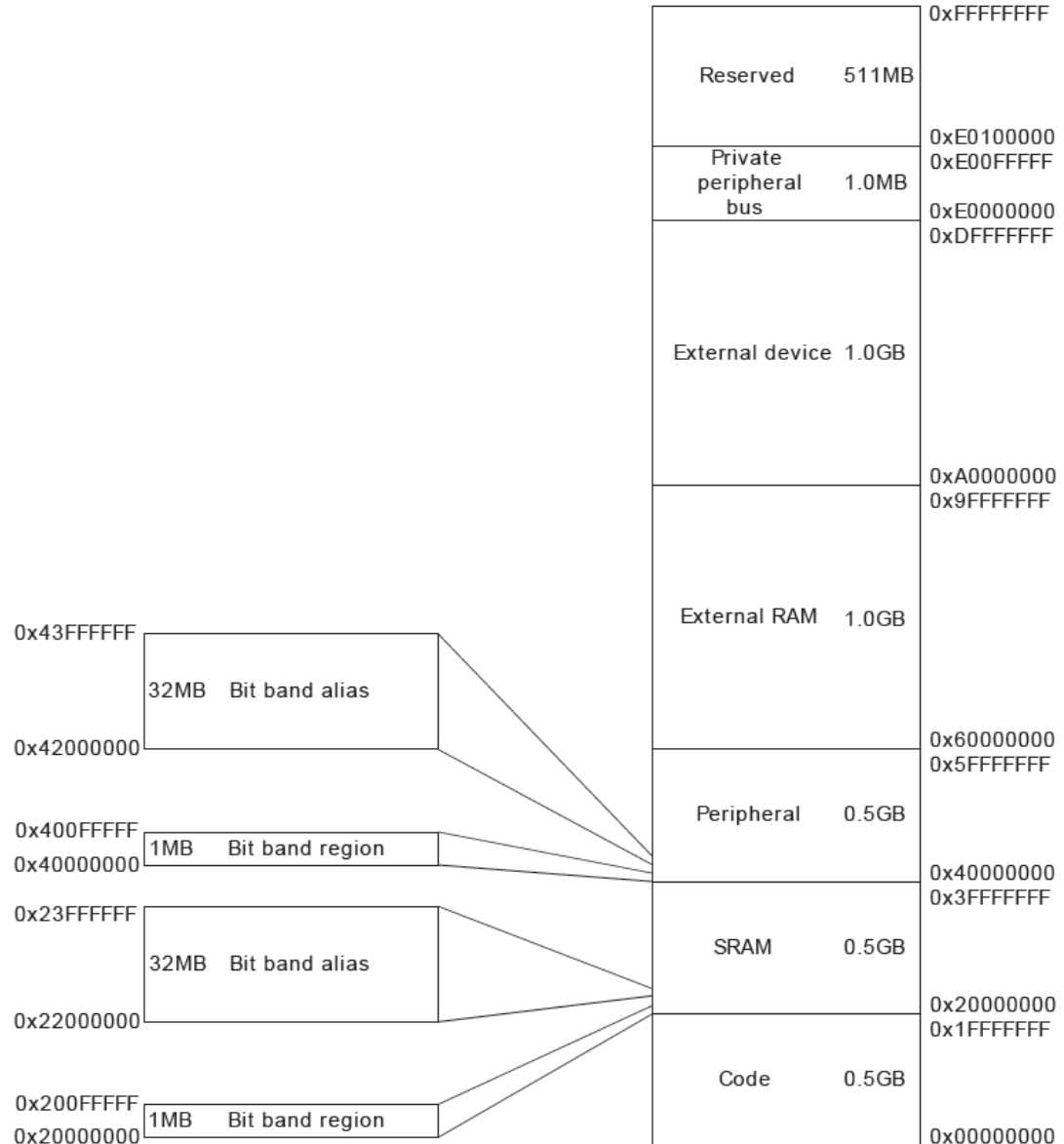

Registers

The processor core registers are:

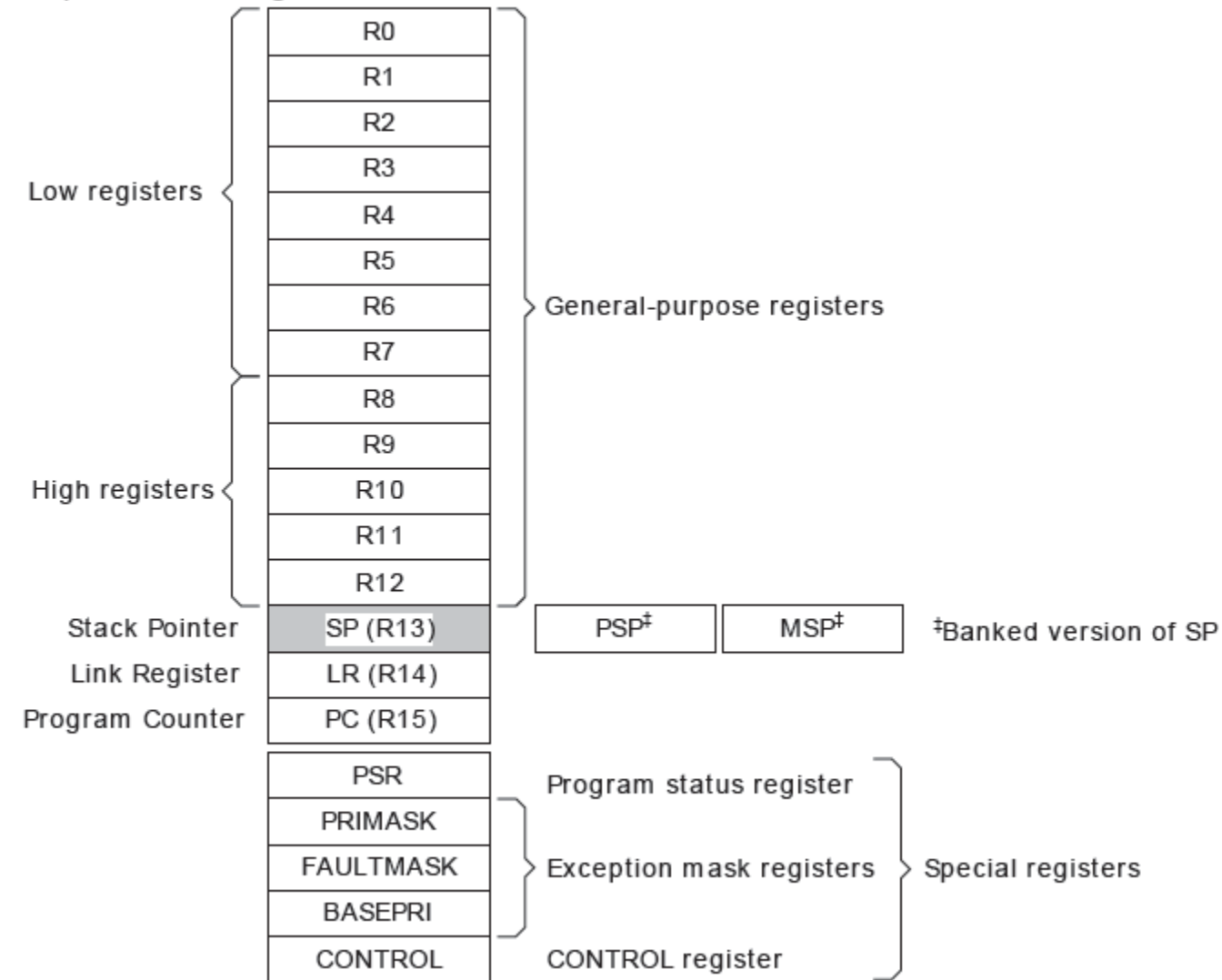

Energy friendly operation

- EFM32: Energy Friendly Microcontroller, 32 bit
- EM0: CPU and all peripherals are in operation → 219 $\mu\text{A}/\text{MHz}$
- EM1: CPU in sleep mode and all peripherals are in operation → 80 $\mu\text{A}/\text{MHz}$
- EM2: only those peripherals are in operation that run on low frequency oscillator → approx. 1 μA
- EM3: low frequency oscillator is off; only some kind of interrupt can wake up the μC → approx. 0.8 μA
- EM4: pins are in reset state; only some kind of interrupt can wake up the μC → approx. 20 nA
- System level consideration: the appropriate EMx mode has to be chosen during system design phase:
 - What peripherals can be used in that EMx mode?
 - How the μC be waken up from that EMx mode?

Clock management

- CMU: Clock Management Unit
- Current consumption is proportional to the clock frequency
 - In CMOS technology static current consumption is negligible, only dynamic behavior (when switching) consumes current
 - CMOS input can be well described by its capacity
 - Charge stored in a capacitor: $Q=C*U$
 - If clock frequency is f , then the maximum number of switching in one second is f , i.e., charge flown \rightarrow current consumption: $I=f*Q=f*C*U$
- Current consumption depends on the voltage
 - In general voltage is a design constraint, but when consumption matters the lower voltage is the better (e.g. in modern processors the core and the peripherals are operated at different voltage levels)
- Clock for non used peripherals can be disabled not to consume energy
- Actual frequency is set by division of source clock frequency
 - Remark: in case of certain processors clock frequency can be scaled up (multiplied) by a PLL
- Internal RC oscillator is also available but its frequency is inaccurate

Clock management

- Different peripherals can be operated at different clock frequencies

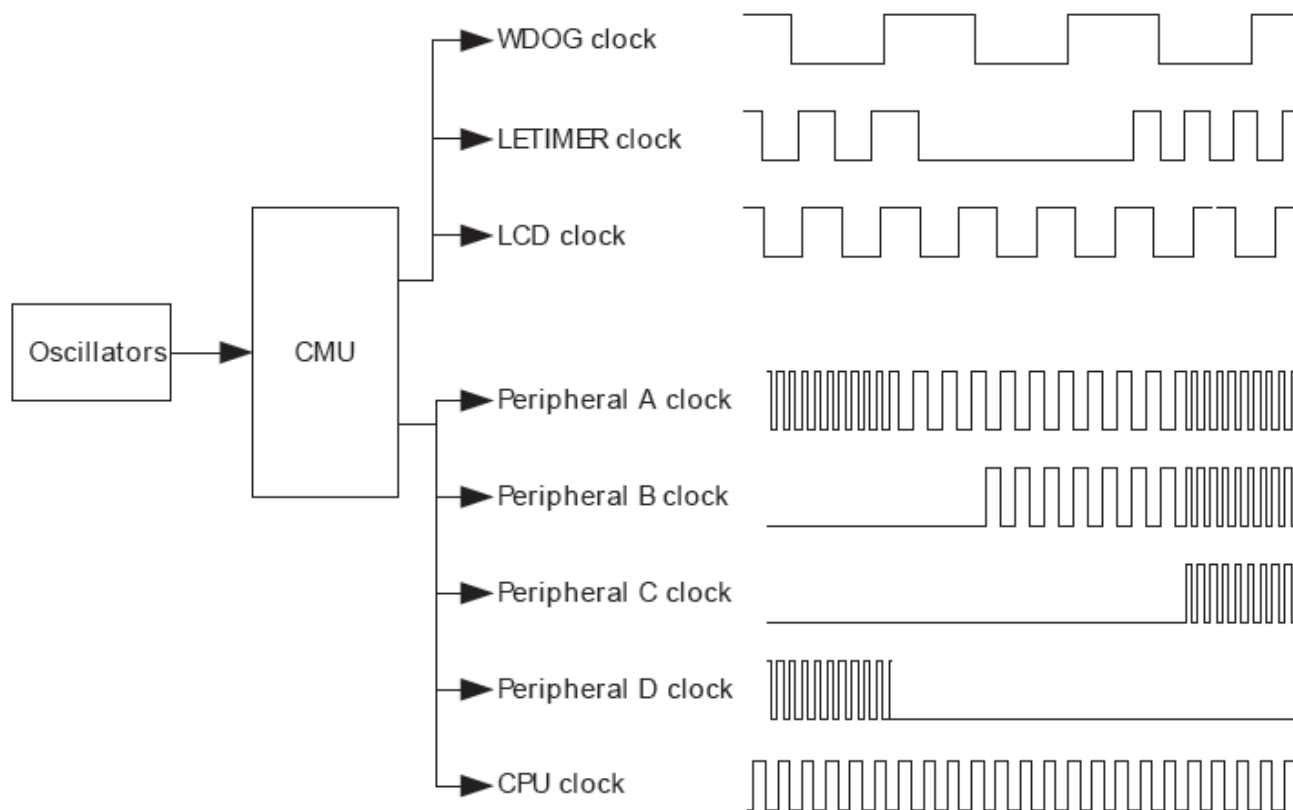

Clock management

■ Configuration:

- The clock source to be used has to be enabled (NOTE: enabling must be first and initialize second, otherwise the processor will stop the operation since no clock will appear)
- The clock source has to be set
 - High frequency CLK
 - Internal RC osc. (1MHz...28MHz)
 - External crystal osc. (max. 48 MHz)
 - Low frequency CLK
 - Internal RC osc.(~32.768 kHz)
 - External crystal osc. (generally 32.768 kHz)
 - Some units are supported by supplementary internal RC oscillator
- Division ratio has to be set
- Clock has to be enabled at the certain peripheral

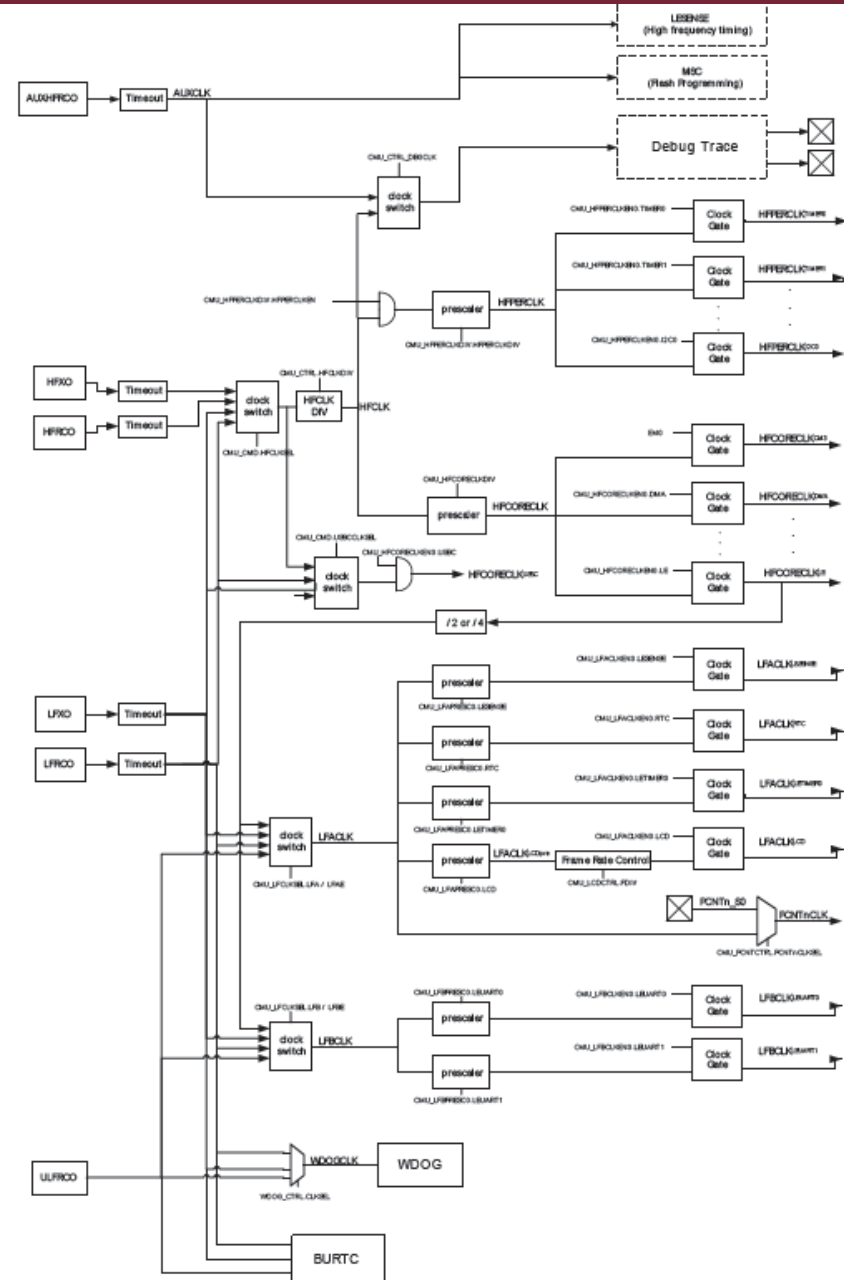

Current consumption

- GPIO: 0.1 mA, 1 mA, 6 mA, 20 mA max current (programmable)



DRIVEMODE 0x0 RW Drive Mode Select
Select drive mode for all pins on port configured with alternate drive strength.

Value	Mode	Description
0	STANDARD	6 mA drive current
1	LOWEST	0.1 mA drive current
2	HIGH	20 mA drive current
3	LOW	1 mA drive current

- ER14505: 3.6 V, 2700 mAh
- 1 mA current consumption
→ 2700 h (~100day) operation
- 0.1 mA current cons. : ~3years
- 10 mA current cons. : ~10days
- See temperature dependence

3. CAPACITY VS. CURRENT

